

Monitored Ball Valve

Model 120 v4

Product Description

Rapidrop Model 120 full bore lockable isolation ball valve designed to meet requirements of BS 9251:2021. The Contactless tamper switch is monitoring the fully open position of the valve and will send a signal to FloWatch or any other monitoring system if the valve is being tampered with.

Commonly used in residential systems as a zone or control valve. The full bore design allows minimal flow restriction and pressure loss.

Maximum Working Pressure

68 bar (1000 psi)

Temperature Range

0° - 80°C

Connections

Female BSP Threads

IP rating

IP54 - tested as per BS EN 60529:1992 + A2:2013

Material specifications

Stainless steel 304 Ball Valve

ABS Switch Enclosure

Switch specification

24V AC/DC

1 VA Switching Capacity

Normally closed or Normally open switch contacts



Features

- IP54 rated (certified) open style enclosure (1) providing easy access for wiring whilst obtaining the maximum IP rating
- Push in resistor connectors for custom rating resistors (2)
- Contactless switch for fail-safe operation (3) no mechanical parts, eliminating the possibility of being tampered with
- External switch connection (4) allows an additional input to be connected onto the same zone, commonly found when installed on a combined BCWS (boosted cold water supply)
- Knock out connectors for M20 cable glands - (5) enabling the wiring connection from either side of the enclosure
- Direct/fix switch mounting plate (6) preventing false alarms as seen with other style retro-fit brackets. The monitoring device can also be removed/ replaced in situ
- Lockable handle with padlock locking pin - allows using any size leather strap/padlock up to 5.5mm (7)
- Factory fitted 100kΩ EOL & Series resistors specific to FloWatch monitoring panel (8) - Remove PCB Jumper if not in use
- Series or Parallel quick configuration (9)
- Normally open or Normally closed quick configuration (10)
- Push in Wago PCB wiring connectors (11)
- Supplied with 1x cable gland for connecting to Flowatch or other alarm device
- QR code printed on the enclosure linked to product datasheet for ease of wiring details

Optional features

Brass keyed alike padlock

Ordering code: RDPAD25-KA02H

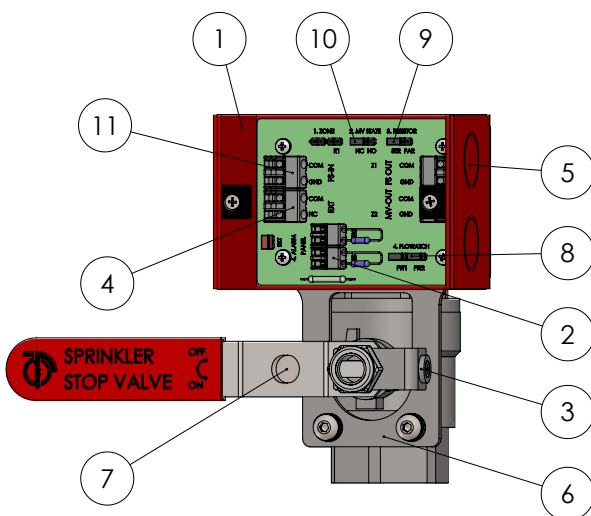

Monitored Ball Valve

Model 120 v4

Installation Guides

The following notes are intended as a basic guide to assist installation and form part of the manufacturers warranty.

- Model 120 Isolation ball valve can be installed in any orientation
- Ensure correct tools are used for installation, never use grip type tools on the ball valve
- Always use pipe sealant compatible with all system components. If in doubts please consult manufacturer's product manual.
- Do not over tighten connecting fittings/components
- Assemble/Restrain the ball valve near to the joint being connected too
- Installation should always be carried out by a suitably qualified person

Knock out removal

- Always remove knock outs with the lid in place
- Push the knock out through by hand or alternatively cut using a knife
- Never use tools to force knock out through - This may cause potential damage of the internal PCB

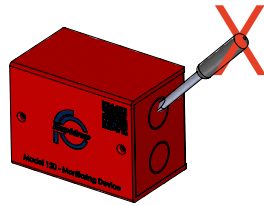

Opening Enclosure Lid

- Undo 2 x lid screws
- Prize the lid away at the bottom. Lift outwards to clear the grooves.
- To install the lid, line the grooves and slide it down, until it engages at the bottom.

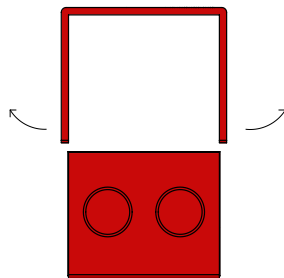

Note: Do not over bend the enclosure lid when lifting outwards

Installation of resistors

- Press down on terminal connection and push in resistor. Once in position remove pressure. Resistor will lock in place

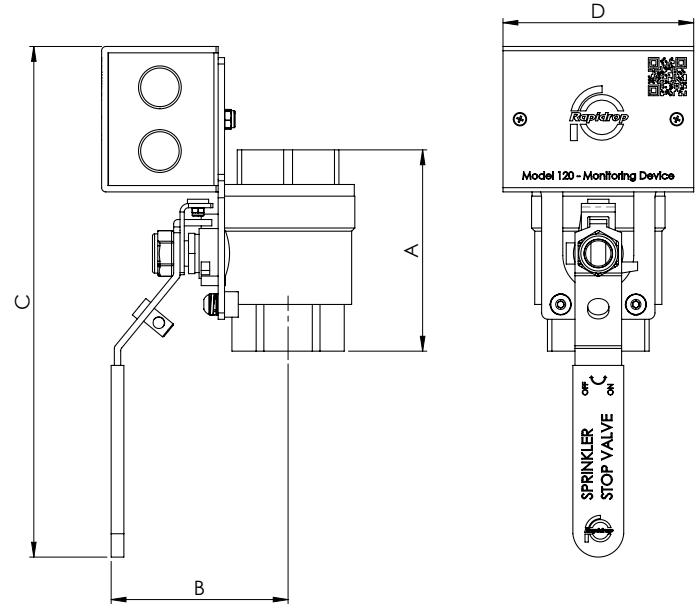
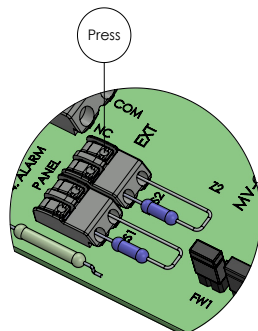

Dimensions

Sizes		Dimensions (mm)				Ordering Codes
mm	inch	A	B	C	D	
DN25	1"	82	72	220	90	RD120MBV025V4
DN32	1-1/4"	95	85	242	90	RD120MBV032V4
DN40	1-1/2"	105	95	265	90	RD120MBV040V4
DN50	2"	118	103	275	90	RD120MBV050V4
DN65	2-1/2"	160	130	310	90	RD120MBV065V4

Configuration

Rapidrop Model 120 utilises PCB Jumpers to easily configure the circuit. Lift the female connectors and re-configure according to the alarm, monitoring system or pump controller you are connecting too.

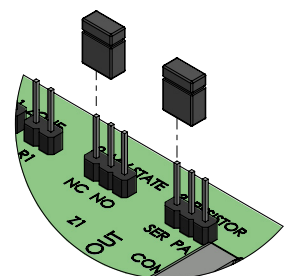

Refer to Wiring/ PCB Jumper configuration section (Page 3)

Wiring Connectors

Push the wire into the terminal to engage.

Note: You will not need to press down onto the terminal.

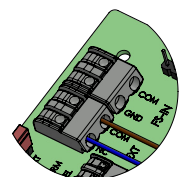

Monitored Ball Valve

Model 120 v4

Wiring/PCB Jumper Configuration

Monitored Valve - Alarm/ Monitoring Panel

Refer to the alarm/monitoring panel manufacturer for switch state/resistor installation

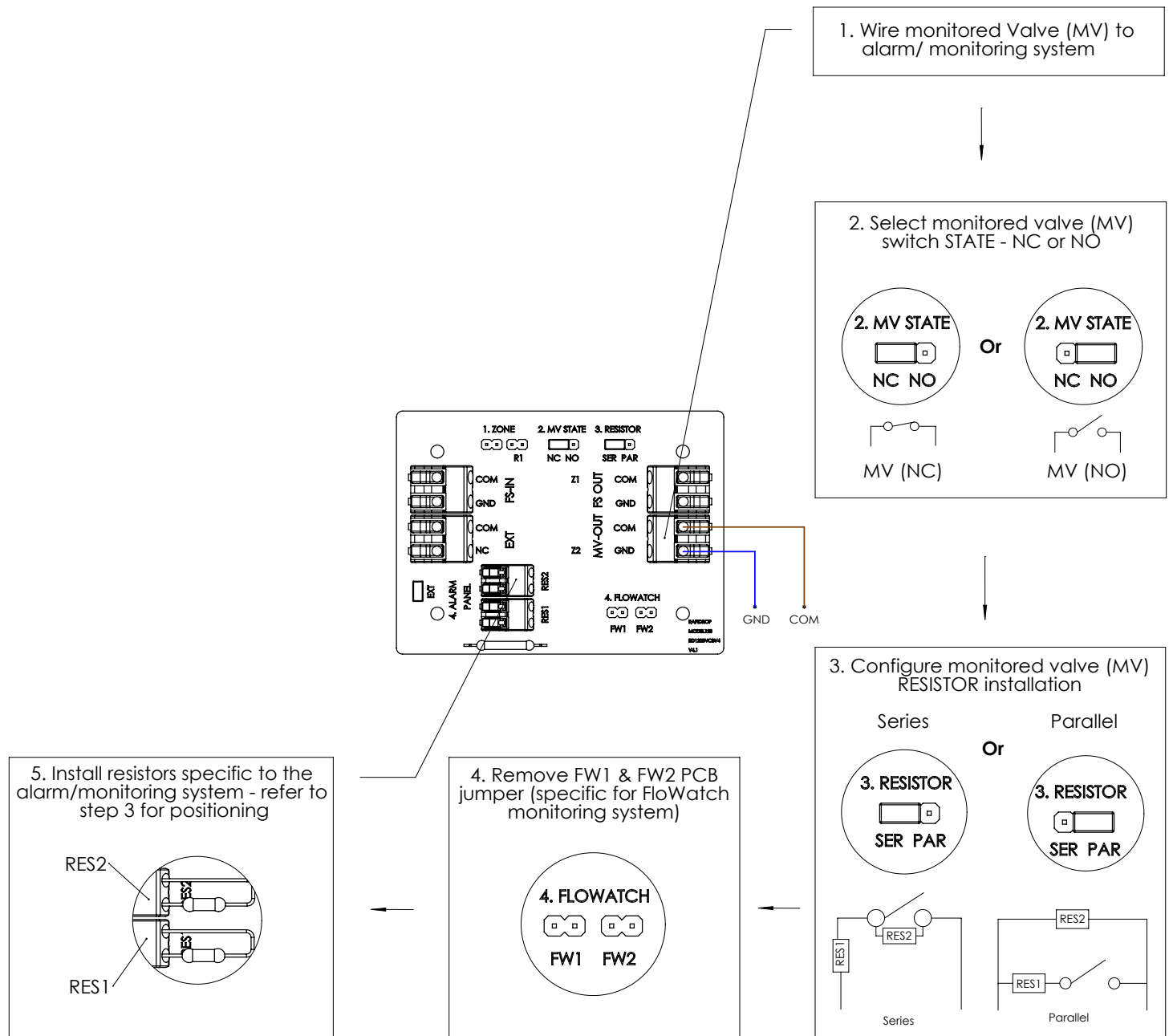

Monitored Ball Valve
Model 120 v4

FloWatch Monitoring System



Set Isolation Valve as NC in programming software

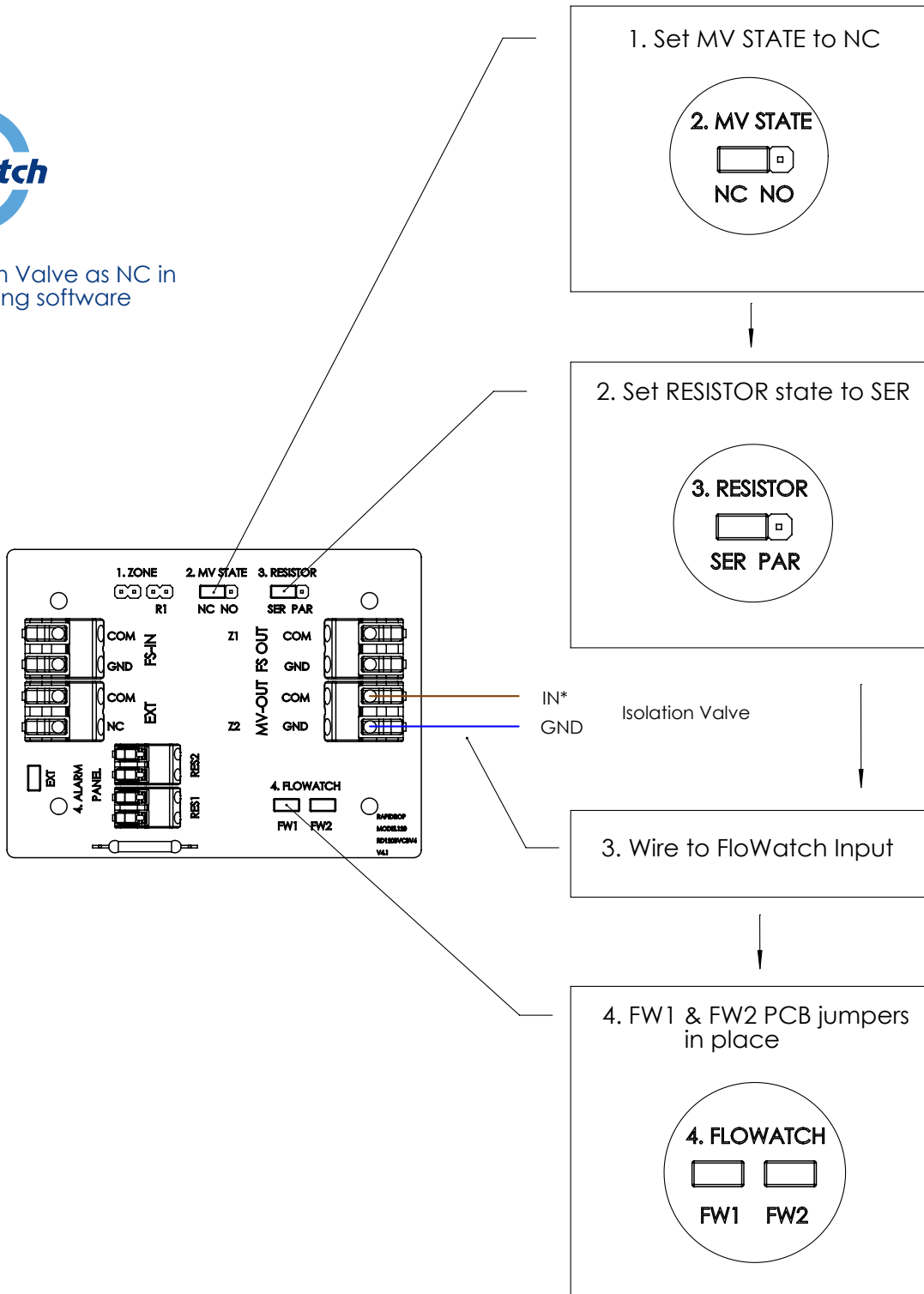

Monitored Ball Valve Model 120 v4

Additional features

Additional external switch - Daisy chain monitored valve input

External switch connection allows an additional input to be connected onto the same zone/ circuit.

Note: The devices will be linked on the same NC circuit (Not independent)

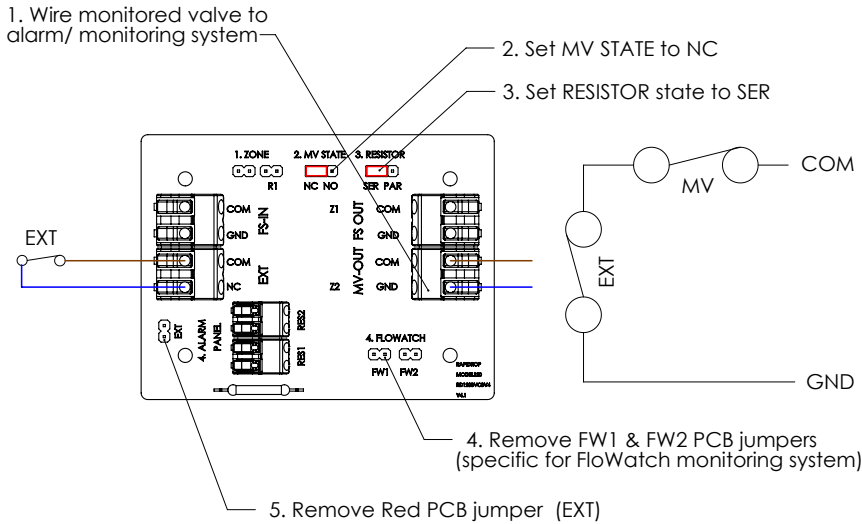

Pump controller Connection - No Resistors

Pump controllers typically utilise voltage circuits rather than resistance. Refer to the below for connection to monitored valve and flow switch. Refer to the pump controller for NC or NO switch state.

Monitored Valve

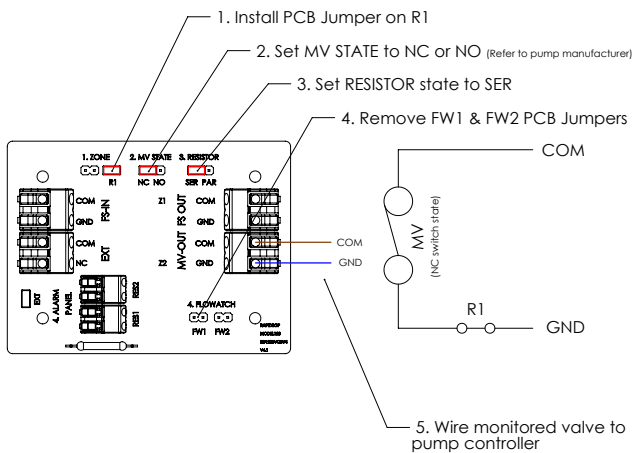

Maintenance

Rapidrop Model 120 monitored ball valve requires no regular maintenance, however it is advisable to inspect and verify proper operation of the unit annually or in accordance with the authority having jurisdiction.

The inspection should include, but not limited to too:

- Verify operation of the tamper switch
- Inspection of magnet (Clean with soapy water if contaminated with external debris)
- Ensure switch enclosure is secure