



## Priority Demand Valve

### Fig. PDV-02V2

BS9251: 2021

### Product Description

Rapidrop's innovative electrically driven Priority Demand valve for use with mains water supply or stored water supply residential sprinkler systems.

Designed to meet BS 9251: 2021 - Valve for isolating domestic supply in the event of sprinkler activation.

Upon activation of a flow switch/alarm relay, the valve will automatically close the domestic supply allowing all water to flow to the sprinkler system and remain closed until manually reset. Upon activation of a low level tank switch (if installed) the valve will automatically close and re-open once the low level tank switch resets itself.

The priority demand valve is available in ball or butterfly type body (depending on connection) attached to a specific actuator (dependant on size) The appropriate PDV control box will need to be ordered separately.

The priority demand valve is available in two different configurations:

- Single PDV - Used in systems designed with a single priority demand valve
- Multiple PDV - Used in systems designed with multiple priority demand valves. Up to 25 PDVs can be simultaneously activated through a single flow switch/ alarm relay.

### Features

#### Ball Valve

- Full Bore
- WRAS approved

#### Butterfly valve

- Stainless steel disc, EPDM liner
- Epoxy coated ductile iron body
- WRAS approved

#### Actuator

- Failsafe close operation (operated by an internal replaceable lithium-Ion battery)
- End of travel relay switch for valve positioning (BMS connection)
- Visual LED indicator for positional identification
- Maximum Allowable 'Stem Torque' to protect valve
- External GSA Connectors (For RAS actuator, M20 Glands for RAM actuator)
- IP67 Rated Actuator
- Maximum of 5W power consumption (24VDC)



### Working Pressure

Max. Working Pressure 16bar (232 psi)  
(Higher pressure range available on request)

### Working Temperature Range

0°C to 70°C (14°F to 158°F)

### Connections

#### Ball valve (DN25 to DN50)

- BSP female thread according to ISO 228/1

#### Butterfly valve (DN50 to DN200)

- Semi lug wafer pattern to suit PN16 Flange according to BS EN 1092 and Table D/E flanges according to BS 10

### Operation

Rapidrop Priority demand valve is a power to open, power to close valve. In the event of power loss the valve will failsafe to the closed position.



Priority Demand Valve  
Fig. PDV-02V2

BS9251: 2021

Ball Valve Dimensions

| Sizes |        | Dimensions (mm) |     |     |     | Flow Rate (KV) |
|-------|--------|-----------------|-----|-----|-----|----------------|
| mm    | Inch   | A               | B   | C   | D   |                |
| DN25  | 1"     | 83              | 140 | 150 | 170 | 43             |
| DN32  | 1 1/4" | 94              | 140 | 150 | 175 | 89             |
| DN40  | 1 1/2" | 102             | 140 | 150 | 187 | 230            |
| DN50  | 2"     | 124             | 140 | 150 | 194 | 265            |

WRAS approval for valve body owned by Brandoni S.P.A

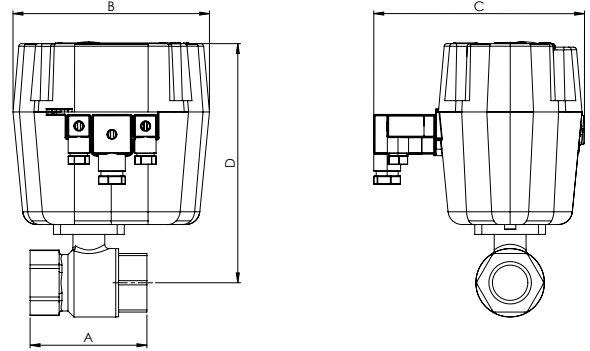

Butterfly Valve Dimensions

| Sizes |        | Dimensions (mm) |     |     |     |     |     |
|-------|--------|-----------------|-----|-----|-----|-----|-----|
| mm    | Inch   | A               | B   | C   | D   | E   | F   |
| DN50  | 2"     | 43              | 140 | 150 | 255 | 62  | 89  |
| DN65  | 2 1/2" | 46              | 140 | 150 | 265 | 69  | 102 |
| DN80  | 3"     | 46              | 203 | 206 | 334 | 90  | 118 |
| DN100 | 4"     | 52              | 203 | 206 | 354 | 106 | 150 |
| DN125 | 5"     | 56              | 203 | 206 | 374 | 119 | 174 |
| DN150 | 6"     | 56              | *   | *   | *   | 133 | 205 |
| DN200 | 8"     | 60              | *   | *   | *   | 166 | 260 |

WRAS approval for valve body owned by Brandoni S.P.A

\* Contact Rapidrop for dimensions

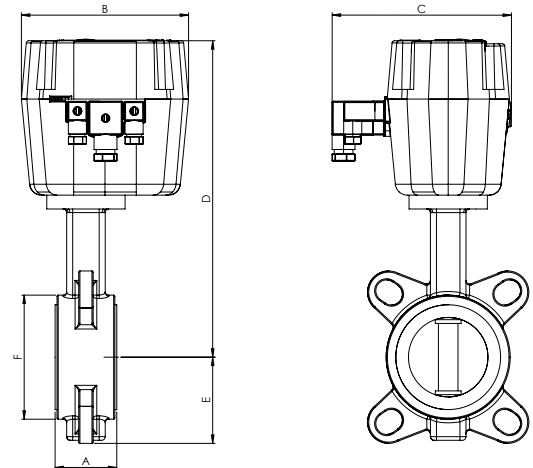

Single PDV System Ordering Codes

| Sizes |        | Isolation Valve | Actuator Model | Ordering Codes   |
|-------|--------|-----------------|----------------|------------------|
| mm    | Inch   |                 |                |                  |
| DN25  | 1"     | Ball Valve      | RAS            | RDPDV-02-025BLV2 |
| DN32  | 1 1/4" | Ball Valve      | RAS            | RDPDV-02-032BLV2 |
| DN40  | 1 1/2" | Ball Valve      | RAS            | RDPDV-02-040BLV2 |
| DN50  | 2"     | Ball Valve      | RAS            | RDPDV-02-050BLV2 |
| DN50  | 2"     | Butterfly Valve | RAS            | RDPDV-02-050V2   |
| DN65  | 2 1/2" | Butterfly Valve | RAS            | RDPDV-02-065V2   |
| DN80  | 3"     | Butterfly Valve | RAM            | RDPDV-02-080V2   |
| DN100 | 4"     | Butterfly Valve | RAM            | RDPDV-02-100V2   |
| DN125 | 5"     | Butterfly Valve | RAM            | RDPDV-02-125V2   |
| DN150 | 6"     | Butterfly Valve | RAM+Gearbox    | RDPDV-02-150V2   |
| DN200 | 8"     | Butterfly Valve | RAM+Gearbox    | RDPDV-02-200V2   |

The above ordering codes include 1x electrically actuated isolation valve only. Appropriate control box need to be ordered separately.

Multiple PDV System Ordering Codes

| Sizes |        | Isolation Valve | Actuator Model | Ordering Codes     |
|-------|--------|-----------------|----------------|--------------------|
| mm    | Inch   |                 |                |                    |
| DN25  | 1"     | Ball Valve      | RAS            | RDPDV-02-025BLV2SM |
| DN32  | 1 1/4" | Ball Valve      | RAS            | RDPDV-02-032BLV2SM |
| DN40  | 1 1/2" | Ball Valve      | RAS            | RDPDV-02-040BLV2SM |
| DN50  | 2"     | Ball Valve      | RAS            | RDPDV-02-050BLV2SM |
| DN50  | 2"     | Butterfly Valve | RAS            | RDPDV-02-050V2SM   |
| DN65  | 2 1/2" | Butterfly Valve | RAS            | RDPDV-02-065V2SM   |
| DN80  | 3"     | Butterfly Valve | RAM            | RDPDV-02-080V2SM   |
| DN100 | 4"     | Butterfly Valve | RAM            | RDPDV-02-100V2SM   |
| DN125 | 5"     | Butterfly Valve | RAM            | RDPDV-02-125V2SM   |
| DN150 | 6"     | Butterfly Valve | RAM+Gearbox    | RDPDV-02-150V2SM   |
| DN200 | 8"     | Butterfly Valve | RAM+Gearbox    | RDPDV-02-200V2SM   |

The above ordering codes include 1x electrically actuated isolation valve only. Appropriate power supply unit and control box need to be ordered separately.



Priority Demand Valve  
Fig. PDV-02V2

BS9251: 2021

Specifications

| Valve Size/ Actuator model | DN25 - DN65 (1" - 2 1/2") RAS Actuator | DN080 - DN125 (3" - 5") RAM Actuator | DN150 - DN200 (6" - 8") RAM Actuator (With Gearbox Attachment) |
|----------------------------|--|--------------------------------------|--|
| Working Time 0-90°         | 8 Seconds                              | 4 Seconds                            | 16 Seconds   |
| Current                    | 0.55A                                  | 0.55A                                | 0.55A  |
| Power Supply               | 12-30V                                 | 12-30V                               | 12-30V   |
| IP Rating                  | IP67                                   | IP67                                 | IP67   |
| End of Travel Relays       | 300VAC/900mA - 30VDC                   | 250VAC/5A - 30VDC                    | 250VAC/5A - 30VDC  |
| Ambient Temp Range         | -20°C to 70°C                          | -20°C to 70°C                        | -20°C to 70°C  |
| Manual Override            | Local Buttons (Disabled as standard)   | Local Buttons (Disabled as standard) | Local Buttons (Disabled as standard)                           |
| Bluetooth Control          | Via Android App                        | Via Android App                      | Via Android App  |
| Cable Entries              | External GSA                           | 2 x M20 Cable Glands                 | 2 x M20 Cable Glands   |

Installation

The valve may be installed in any position and the flow may be from either direction through the valve.

1. Visually inspect the valve, make sure that the connections are clean of debris and any foreign materials.
2. Mount/connect the valve to the pipework (Valve in the closed position) **Note for butterfly valve bodies do not over torque the flange. This may distort the rubber seal.**
3. Wire the valve following the below sequence;

RAS - Remove the lid by undoing the 4 bolts using a 3mm allen key. **Connect the battery** within the actuator using the nylon male/female plug. Re-assemble the lid cover. Undo the centre GSA screw using a Phillips or flat-head screwdriver. Wire as per wiring diagram. Re-assemble the GSA plug onto the actuator.

RAM - Remove the lid by undoing the 6 bolts using a 3mm allen key. **Connect the battery** within the actuator using the nylon male/female plug. Disconnect the terminal block and wire as per wiring diagram. Re-assemble the lid.

4. Functional test the operation of the valve via the flow switch or relay. The solid green LED will indicate the valve is in the open position. The solid red LED will indicate the valve is in the closed position
5. The internal battery is disconnected for storage/travel and to prevent detriment to the battery. During commissioning or after, if the PDV is going to be unpowered for a prolonged period (Over 1 year RAS & over 1 month RAM) we recommend disconnecting the battery to secure its longevity.

Note: The PDV should be wired by a qualified electrician. Follow relevant safety procedures when handling the circuit board.

Connection of battery

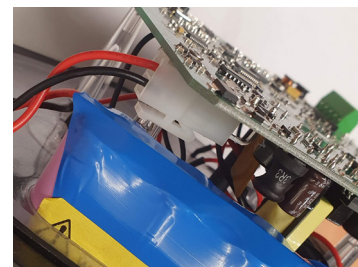

RAS - GSA Connector



RAM terminal block

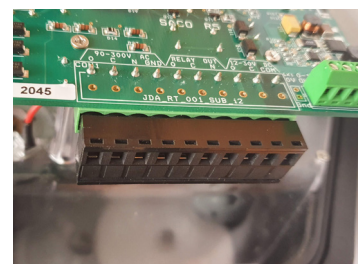



# Priority Demand Valve Fig. PDV-02V2

BS9251: 2021

### Control Box - Single PDV Systems

- Upon activation of a flow switch or alarm relay, the PDV will automatically latch in the closed position, it will remain closed until the control box is manually reset (via the blue reset button)
- Upon activation of a low tank level switch, the PDV will automatically close, it will automatically open once the low tank level switch resets itself.
- Upon loss of power to the PDV/control box the valve will failsafe to the closed position. It will automatically reopen once power is restored.
- Designed to meet the requirements of BS9251: 2021

### RDPDVBOXLATCH



### Features

- Metal IP66 wall mounted enclosure
- Internal DIN rail mount terminals for connection of:
  - Flow Switch/ Alarm Relay
  - Tank Low Level Switch
  - Power supply connection to PDV
  - End of travel relay to PDV
  - External Dry Contact for BMS
- LED to indicate the current position of the valve (Green LED - valve fully open, Red LED - valve fully closed)
- Manual momentary reset button
- Power supply requirements: 230V AC connected to a 3A fused spur
- Internal 3A MCB

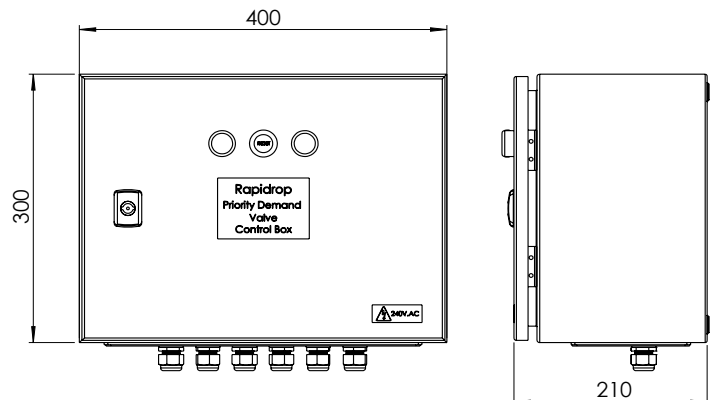

| Description            | Ordering Code |
|------------------------|---------------|
| Single PDV Control Box | RDPDVBOXLATCH |

# Priority Demand Valve

## Fig. PDV-02V2

BS9251: 2021

Single PDV Wiring Diagram

RDPDVBOXLATCH - RAS (2 1/2" <)

Power Supply (24V)

| RAS Wiring Numbers |             |
|--------------------|-------------|
| Center Connector   | Control Box |
| 1                  | 25          |
| 2                  | 27          |
| 3                  | 26          |

Relay Out

| RAS Wiring Numbers |             |
|--------------------|-------------|
| Right Connector    | Control Box |
| 1                  | 28          |
| 2                  | 30          |
| 3                  | 29          |

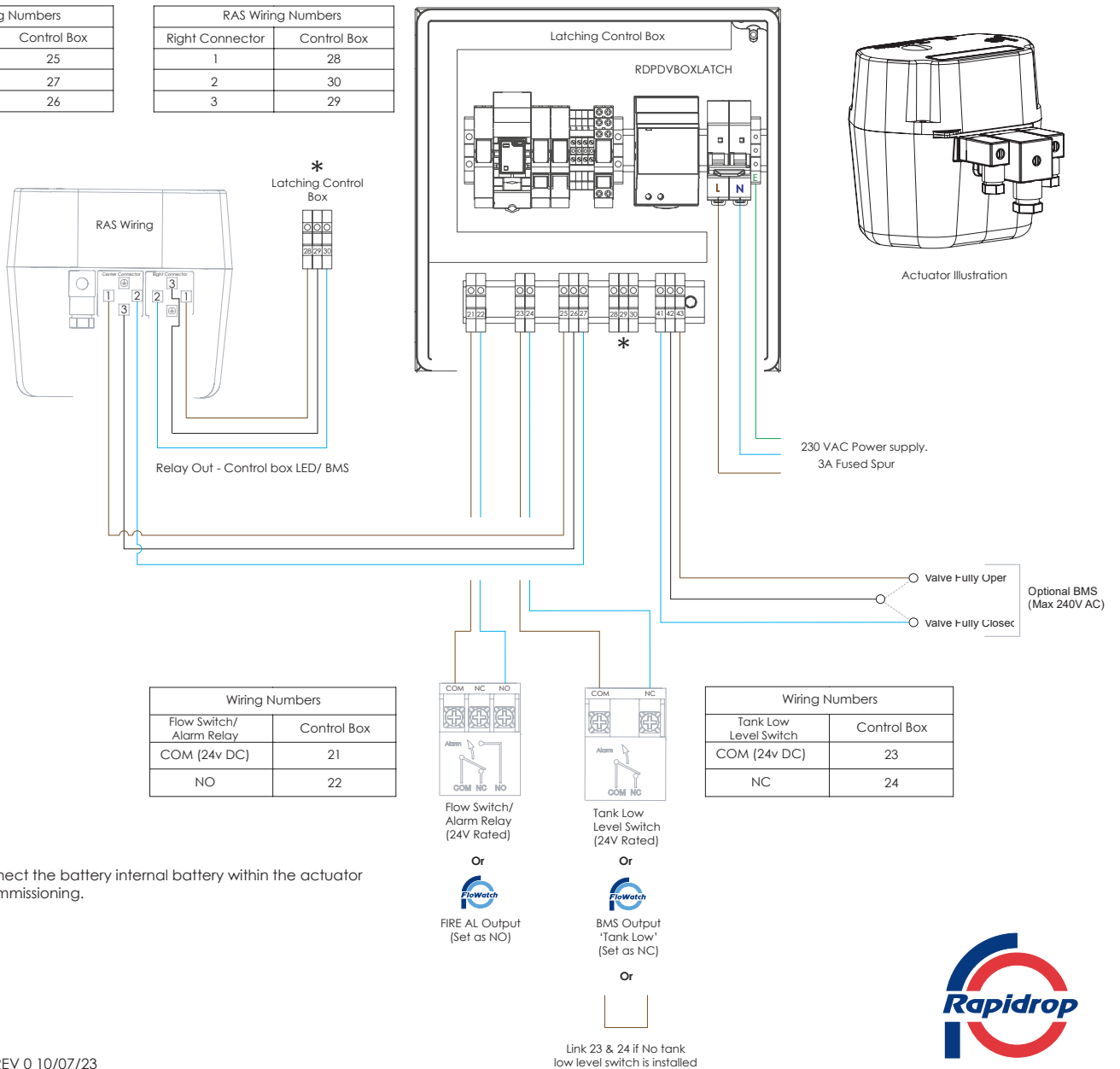

| Wiring Numbers           |             |
|--------------------------|-------------|
| Flow Switch/ Alarm Relay | Control Box |
| COM (24v DC)             | 21          |
| NO                       | 22          |

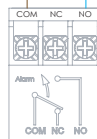

Flow Switch/ Alarm Relay (24V Rated)

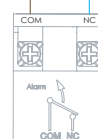

Tank Low Level Switch (24V Rated)

| Wiring Numbers        |             |
|-----------------------|-------------|
| Tank Low Level Switch | Control Box |
| COM (24v DC)          | 23          |
| NC                    | 24          |



FIRE AL Output (Set as NO)



BMS Output 'Tank Low' (Set as NC)

Link 23 & 24 if No tank low level switch is installed

Note: Connect the battery internal battery within the actuator prior to commissioning.

RAP-MSC-321 REV 0 10/07/23



# Priority Demand Valve

## Fig. PDV-02V2

BS9251: 2021

### Single PDV Wiring Diagram

#### RDPDVBOXLATCH - RAM (3" >)

Power Supply (24V)

| RAM Wiring |             |
|------------|-------------|
| Actuator   | Control Box |
| O          | 25          |
| C          | 27          |
| COM        | 26          |

Note: Use the 12-30V DC Connection within the isolation valve

Relay Out

| RAM Wiring |             |
|------------|-------------|
| Actuator   | Control Box |
| O          | 28          |
| N          | 29          |
| C          | 30          |

Note: Use the Relay Connection within the isolation valve

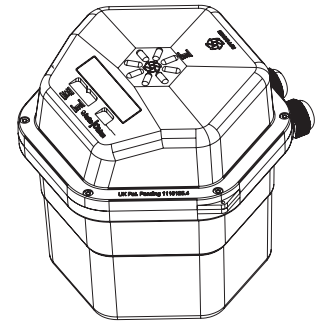
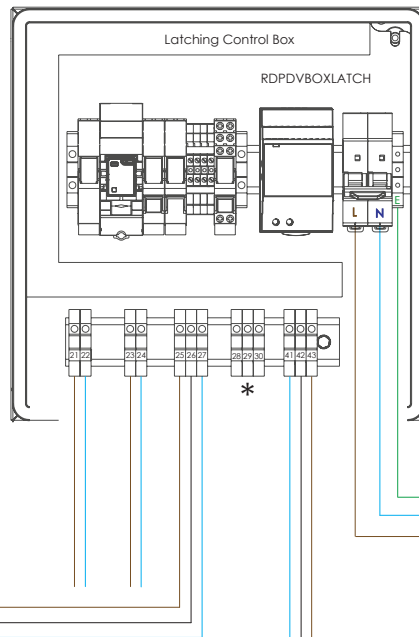
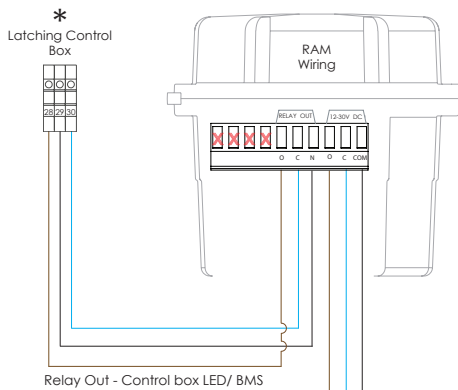

Actuator Illustration

230 VAC Power supply.  
3A Fused Spur

Valve Fully Open  
Valve Fully Closed  
Optional BMS (Max 240V AC)

| Wiring Numbers           |             |
|--------------------------|-------------|
| Flow Switch/ Alarm Relay | Control Box |
| COM (24v DC)             | 21          |
| NO                       | 22          |

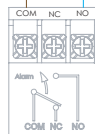

Flow Switch/ Alarm Relay (24V Rated)



FIRE AL Output (Set as NO)

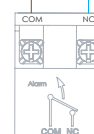

Tank Low Level Switch (24V Rated)



BMS Output 'Tank Low' (Set as NC)



Link 23 & 24 if No tank low level switch is installed

| Wiring Numbers        |             |
|-----------------------|-------------|
| Tank Low Level Switch | Control Box |
| COM (24v DC)          | 23          |
| NC                    | 24          |

Note: Connect the battery internal battery within the actuator prior to commissioning.

RAP-MSC-322 REV 1





# Priority Demand Valve Fig. PDV-02V2

BS9251: 2021

## Control Boxes - Multiple PDV Systems

Rapidrop's priority demand valve can be linked to activate up to 25 valves simultaneously through a single flow switch/alarm relay.

- Upon activation of a single flow switch or alarm relay. All connected PDV will automatically latch in the closed position and will remain closed until the control box is manually reset (via the blue reset button)
- Upon activation of a low tank level switch, all connected PDV will automatically close and will automatically open once the low tank level switch resets itself.
- Upon loss of power to the PDV/control box all valves will failsafe to the closed position. They will automatically reopen once power is restored.
- Designed to meet the requirements of BS9251: 2021

One 'multiple priority demand valve power supply unit' can power up to 7 'multiple priority demand valves'

One 'multiple priority demand valve control box' can control up to 25 'multiple priority demand valves'

For linking more than 25 priority demand valves contact Rapidrop representative for more information.

## Features

- Metal IP66 wall mounted enclosure
- Manual momentary reset button
- Internal DIN rail mount terminals for connection of:
  - Flow Switch/ Alarm Relay
  - Tank Low Level Switch
  - PDV control circuit
- Internal Miniature circuit breaker.
- Power supply requirements: 230V AC connected to a 3A fused spur

## RDPDVBOXLATCHSM

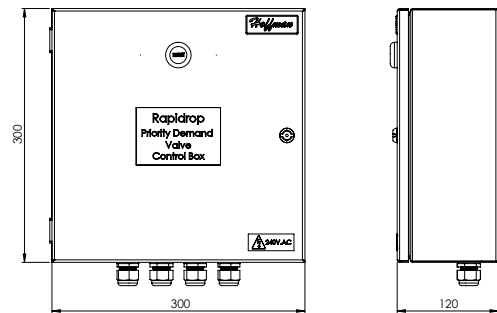

## RDPDV-PSU

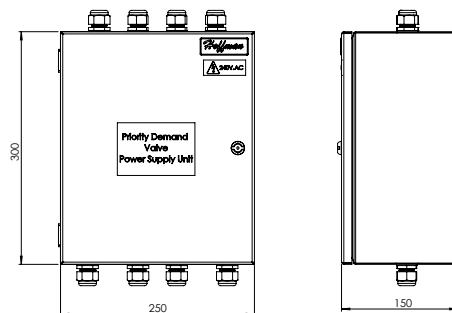

| Description                                      | Ordering Codes  |
|--|-----------------|
| Multiple Priority Demand Valve Control Box       | RDPDVBOXLATCHSM |
| Multiple Priority Demand Valve Power Supply Unit | RDPDV-PSU       |



## Priority Demand Valve Fig. PDV-02V2

BS9251: 2021

### Multiple PDV Wiring Diagram

### 'RDPDVBOXLATCHSM with RDPDV-PSU'

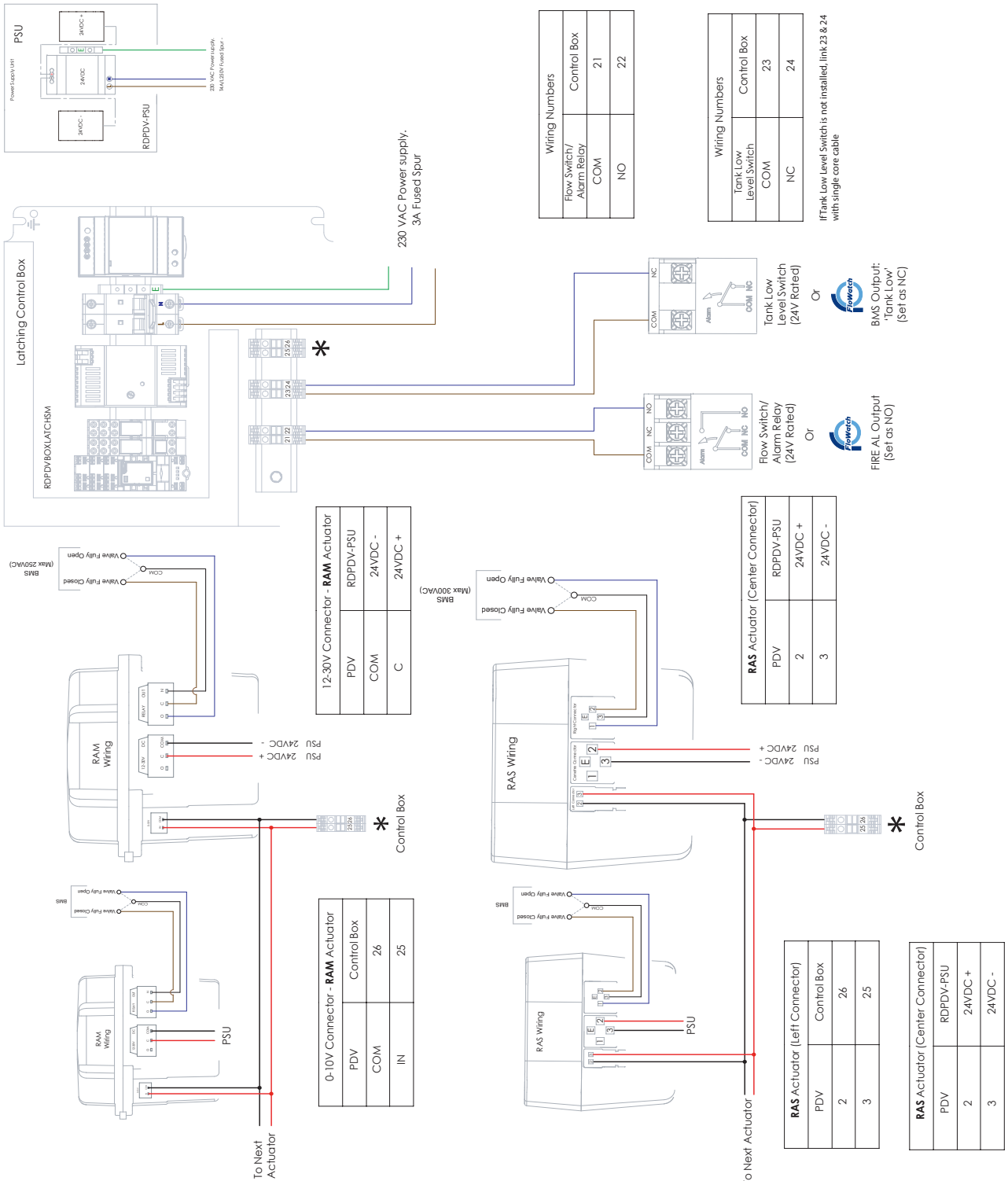

Flow Switch/  
Alarm Relay  
COM  
NO

Tank Low  
Level Switch  
COM  
NC

IF Tank Low Level Switch is not installed, link 23 & 24 with single core cable

Flow Switch/  
Alarm Relay  
COM NC  
NO

Flow Switch/  
Alarm Relay  
COM NC  
NO

| 12-30V Connector - RAM Actuator |           |         |         |
|---------------------------------|-----------|---------|---------|
| PDV                             | RDPDV-PSU | 24VDC - | 24VDC + |
| COM                             |           |         |         |
| C                               |           |         |         |

| RAS Actuator (Center Connector) |           |         |         |
|---------------------------------|-----------|---------|---------|
| PDV                             | RDPDV-PSU | 24VDC + | 24VDC - |
| 2                               |           |         |         |
| 3                               |           |         |         |

| 0-10V Connector - RAM Actuator |             |    |    |
|--------------------------------|-------------|----|----|
| PDV                            | Control Box | 26 | 25 |
| COM                            |             |    |    |
| IN                             |             |    |    |

| RAS Actuator (Left Connector) |             |    |    |
|-------------------------------|-------------|----|----|
| PDV                           | Control Box | 26 | 25 |
| 2                             |             |    |    |
| 3                             |             |    |    |

| RAS Actuator (Center Connector) |           |         |         |
|---------------------------------|-----------|---------|---------|
| PDV                             | RDPDV-PSU | 24VDC + | 24VDC - |
| 2                               |           |         |         |
| 3                               |           |         |         |





Priority Demand Valve  
Fig. PDV-02V2

BS9251: 2021

Operation/ Function Guide

RAS Actuator Model DN24-DN65 (1" - 2 1/2")

LED Function Table

| LED                      | LED Colour         | LED Function               |
|--------------------------|--------------------|----------------------------|
| A - Bluetooth            | Solid Blue         | Paired                     |
|                          | Off                | Asleep                     |
|                          | Flashing Blue      | Awake Bluetooth not paired |
| B - Charging             | Solid Blue         | Charging                   |
|                          | Off                | Charged                    |
| C - Direction/ Operation | Green Solid        | Open                       |
|                          | Green Flashing     | Opening                    |
|                          | Red Solid          | Closed                     |
|                          | Red Flashing       | Closing                    |
|                          | Slow Orange Flash  | Manual Mode                |
|                          | Rapid Orange Flash | Over Torque                |

Note : The touchpad button text is not related to the LED function (D)

RAS Actuator  
LED Illustration

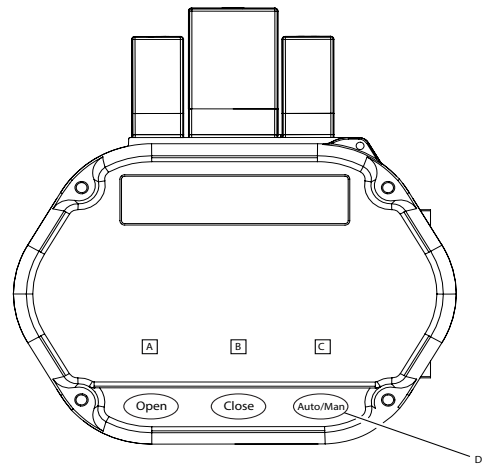

RAM Actuator  
LED Illustration

RAM Actuator Model DN80-DN200 (3" - 8")

LED Function Table

| Illustration Number | LED Colour     | LED Function                          |
|---------------------|----------------|---------------------------------------|
| 1                   | Rotating Green | Valve Opening                         |
| 2                   | Flashing Green | Connected to Bluetooth                |
| 3                   | Solid Green    | Valve Open                            |
| 4                   | Rotating Red   | Valve Closing                         |
| 5                   | Solid Red      | Valve Closed                          |
| 6                   | Flashing Red   | Valve is in Manual Mode               |
| 7                   | Flashing Amber | Valve failed to complete move in time |
| 8                   | Flashing Amber | Reached Max Torque                    |
| 9                   | Flashing Amber | Battery Voltage Low                   |

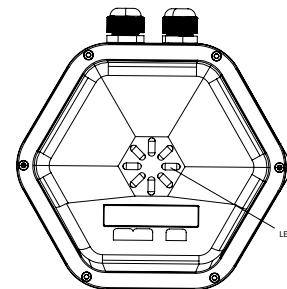
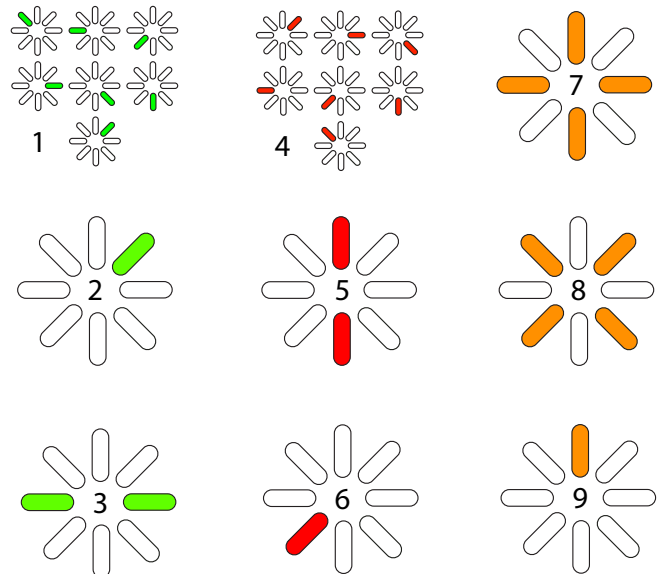



### Priority Demand Valve

#### Fig. PDV-02V2

BS9251: 2021

#### Troubleshooting guide

| Issue                        | Cause   | Corrective Action   |
|------------------------------|---|---|
| PDV Not Powering On          | Power Supply/Battery  | <ul style="list-style-type: none"> <li>• Check Battery Connected</li> <li>• Check Battery Voltage (refer to maintenance for correct voltage)</li> <li>• Check Wiring Diagram</li> </ul>   |
| Over torque                  | Over tightened flange causing the valve seat to distort or foreign body within pipe | <ul style="list-style-type: none"> <li>• Loosen flange bolts to try to rectify valve seat distortion</li> </ul>   |
| Battery Low                  | Battery   | <ul style="list-style-type: none"> <li>• Power the PDV (this will allow the battery to charge)</li> <li>• Replace the battery</li> <li>• Charge the battery for a minimum of 1 hour (Or longer if the battery is very low)</li> </ul> |
| Valve Not Functioning        | Potential PCB sensor location   | <ul style="list-style-type: none"> <li>• Ensure the PCB is fixed in place as supplied</li> <li>• Ensure the Actuator lid is fixed in place (RAS)</li> </ul>   |
| Valve failed to move in time | Actuator taken longer than the pre-set time to move                                 | <ul style="list-style-type: none"> <li>• Contact Rapidrop to modify settings</li> </ul>   |

The table above is intended as a guide. Please call Rapidrop for any queries

#### Care and Maintenance

The priority demand valve requires very little maintenance.

- Ensure all valve body connecting bolts are securely fastened
- Ensure the battery is fully charged, 8V (RAS), 15.8V (RAM)

An orange flashing LED light indicates the battery requires regenerating or replacing. Rapidrop recommend replacing the battery every 3 years at a minimum to prevent detriment of the system.

General control box considerations including but not limited to;

- Ensure all terminals/wires are secure
- Insulation resistance test
- Ensure all relays are correctly engaged

It is advisable to inspect and verify the operation of the unit annually or in accordance with the authority having jurisdiction.

#### Important information

- The installation and maintenance of the priority demand valve must only be made by qualified personnel.
- Ensure electrical installation is as per BS 9251: 2021
- Before removing any covers, always make sure the power supply to the control unit is shut off.
- Failure to follow these instructions could cause improper operation, resulting in personal injury and/or property damage.
- For further details and technical support please contact your Rapidrop sales representative.

#### Battery

The actuator is powered through the battery meaning it is 'power to open' and upon activation of the failsafe feature the valve will close.

It is recommended that mains power is connected within 1 month of receiving the PDV.

The battery is supplied fully charged and disconnected from the actuator. Battery connector is push fit located underneath the PCB board this should be attached immediately prior to connection to mains power.

The battery is designed to be only used in failsafe mode. (e.g., Power outage) Repeated operation under battery power will rapidly drain the battery voltage beyond ability disabling the valve.