

Residential Lead Free Flat Concealed Pendent, K3.0

Model: RD207

General Description

The model RD207 residential flat concealed sprinklers are automatic sprinklers of the compressed fusible solder type. These are decorative and fast response. The cover plate assembly hides the deflector, heat responsive element etc., which is in turn concealed above the ceiling. The cover plate has a flat profile, and its diameter is extremely small 68mm (2-5/8"). The push-on and/or thread-on, thread-off design of the concealed cover plate assembly allows easy installation of the cover plate. Therefore, the model RD207 should be your first choice when aesthetics is the major consideration for ultimate appeal and unbeatable performance is desired. The Model RD207 is designed for the residential occupancies and it is perfect for use in homes, hotels and other living quarters.

Model RD207 is suitable for BS9251, (BS)EN16925 residential sprinkler systems, wet pipe residential sprinkler systems for one and two Family Dwelling and manufactured homes as per NFPA13D; wet pipe residential sprinkler systems for residential occupancies up to and including four Stories in height per NFPA 13R; or, wet pipe sprinkler systems for the residential portions of any occupancies per NFPA 13.

Model RD207 has a 3.0 (43.2 LPM/√ bar) K-Factor that meets the required residential flow rates with minimal residual pressure, which allows for smaller pipe sizes and water supply requirements. For extended installation flexibility, the model RD207 provides 12.8mm (1/2") vertical adjustment. This adjustment in installation decreases the need for precise cutting of the pipe, that drops to the sprinkler and allows for a perfect fit with a range of pipe lengths. The heat sensitivity and water distribution design of model RD207 allows for an increased chance of residents' escape or evacuation in case of fire. However, residential fire sprinkler systems are not a substitute for fire safety awareness or fire safety construction required by building codes.

"Lead Free" is defined in the reduction of lead in drinking water act (S.3874) endorsed by AWWA's water utility council, and California assembly bill #1953 as having less than or equal to a weighted average of 0.25% lead in wetted surface of pipes, plumbing fittings and fixtures.

Technical Data

Item Number	Description
Approvals	cULus listed to UL199 (replaces UL1626) UL-EU listed to (BS)EN12259-14
Model	RD207
Max. Working Pressure	12 bar (175 psi)
Discharge Coefficient	K43 (K3.0)
Temperature Rating (Colour Code)	Sprinkler: 72°C / 162°F (Uncoloured)* Cover Plate: 60°C / 140°F (No Mark) Sprinkler: 96°C / 205°F (White) Cover Plate: 72°C / 162°F (White Mark)
Vertical Adjustment	12.8 mm (1/2")
Finishes	White, Ivory, Beige, Brown, Black, Nickel, Wood Grain or Custom painted
Physical Characteristics	Ref. Figure 1 and 1.1

*UL-EU Listed 72°C (162°F) only

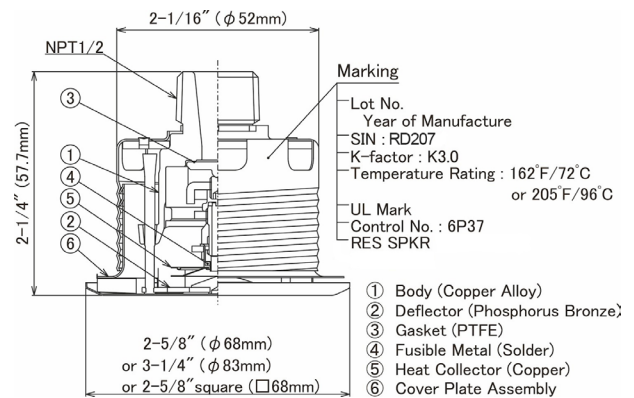

Figure 1

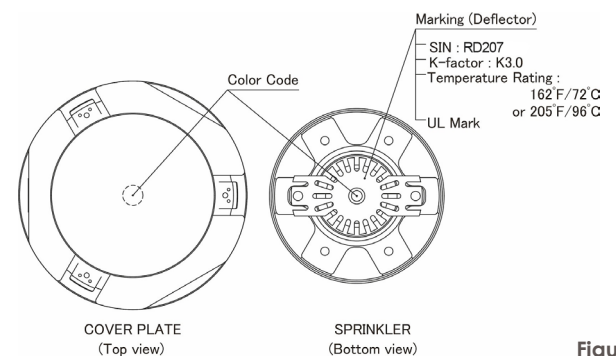
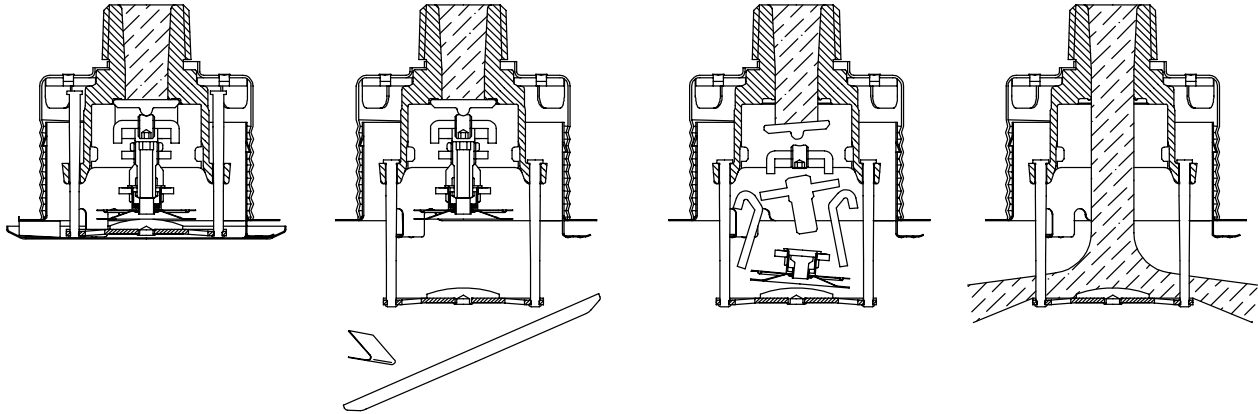

Figure 1.1

Residential Lead Free Flat Concealed Pendent, K3.0

Model: RD207



Normal Condition → Cover Plate Operation → Sprinkler Operation → Water Discharge **Figure 2**

Warnings

The model RD207 must be installed and maintained in accordance with the rules stated herein as well as in compliance with the applicable standards of the national fire protection association regulations and the standards of any other authorities having jurisdiction.

In the event of this condition, consult the authorities having jurisdiction for guidance and approval. Failure to do so may impair the integrity of these devices. It is the responsibility of the installing contractor to provide a copy of this document to the owner or his representative, and in turn, it is the obligation of the owner to provide a copy of this document to a succeeding owner. The owner is responsible for maintaining their fire protection system and devices in proper operating condition. The installing contractor or sprinkler manufacturer should be contacted with any related questions.

Operation

In case of fire, the solder component that holds together the cover plate and the retainer, melts. Then, the cover plate is released at once. As a result, the deflector drops down to the intended position. Two heat collectors are exposed to fire, and when sufficient heat from the fire is recorded, internal components of the sprinkler fall apart. This leads to allow the water flow to be distributed on the affected fire area. (Ref. Figure 2)

Design Criteria

The rules stated herein for use and installation of model RD207 are provided by the manufacturer and must be strictly implemented for safe and full results.

Notes

Residential fire sprinkler systems should only be designed and installed by individuals who are completely familiar with automatic sprinkler system design, installation procedures and techniques. Several criteria may apply to the installation and usage of each sprinkler.

Consequently, it is recommended that the sprinkler system designer review and develop a working understanding of the complete list of criteria, prior to initiating the design of the sprinkler system. Questions concerning sprinkler installation and usage criteria, which are not covered by the following instructions, should be submitted to Rapidrop. Include sketches and technical details as appropriate. In some instances, the requirements of this document may concern specifications which are more stringent and which take precedence over those specified in NFPA 13, 13D, 13R, or by the authority having jurisdiction.

The model RD207 must not be used in applications where the air pressure above the ceiling is greater than that below.

The spray from the sprinkler is distributed outward and downward from the sprinkler deflector. Consequently, the sprinklers must be located such that there will be no blind spaces shielded from spray by partitions, room dividers, overhangs or other parts of the dwelling structure.

The number of sprinklers within each compartment (as defined in BS9251, (BS)EN16925, NFPA13D, 13R or 13) must be kept as few as possible while observing all guidelines relating to obstructions and spacing.

Use only the cover plate provided with the model RD207. The sprinkler must be secured in place by firmly fastening the sprinkler system piping to the structure. If the sprinkler is not properly secured in position, reaction forces resulting from sprinkler operation could alter its orientation and its water distribution pattern.

Obstruction to Water Distribution

Locations of sprinklers must follow the obstruction rules of BS9251, (BS)EN16925 or NFPA13 for residential sprinklers.

General Service Conditions

The model RD207 must only be utilised in WET PIPE sprinkler systems.



Residential Lead Free Flat Concealed Pendent, K3.0

Model: RD207

Heat Source Criteria

Refer to BS9251, (BS)EN16925, NFPA 13D or 13R for the requirements relating to the prevention of possible activation of the Heat Responsive Element of model RD207, due to exposure to a heat sources rather than an actual fire.

Available Sprinkler Temperature Ranges			
Sprinkler Temperature Classification	Sprinkler Nominal Temperature Rating	Maximum Ambient Ceiling Temperature	Temperature Rating of the Cover Plate Assembly
Ordinary	72°C (162°F)	38°C (100°F)	60°C (140°F)
Intermediate	96°C (205°F)	66°C (150°F)	72°C (162°F)

Precautary Warning for Corrosive Environments

The model RD207 should not be installed where they may be subjected to a corrosive environment including the following:

(1) Chlorine ion and Chloride environment

Stress corrosion cracking may be caused by exposure to environments with chlorine ion and chloride. Exposure to this environment may result in sprinklers operating under non-fire conditions or not operating when exposed to an actual fire.

(2) Sprinkler system piping with Copper

Sprinkler systems should be constructed in compliance with the applicable standards and the requirements for the copper piping when copper piping is used in the sprinkler system. (Reference standards NFPA 13, ASTM B813, B828, and CDA (Copper Development Association) – solder joint)

All residual flux must be removed from the interior and exterior of copper piping by thoroughly flushing before installation of the sprinkler heads. Otherwise, residues of flux may cause corrosion and leakage in the sprinkler system.

Hydraulic Design Criteria

The minimum required sprinkler flow rates for system designed to BS9251, (BS)EN16925, NFPA13D or 13R are given in Table A as a function of temperature rating and the maximum allowable coverage areas. The sprinkler flow rate as specified in NFPA 13D or 13R is the minimum required discharge from the most hydraulically demanding sprinkler from each of the total number of 'design sprinklers'.

For systems designed to NFPA 13, the number of designed sprinklers is to be the four most hydraulically demanding sprinklers. The minimum required discharge from each of the four sprinklers is to be the greater of the followings;

- The flow rates given in Table A for NFPA 13D and 13R as a function of temperature rating and maximum allowable coverage area
- A minimum discharge 0.1GPM/sq.ft. [4.07(L/min)/ sq.m] over the "design area" comprised of the four most hydraulically demanding sprinklers for the actual coverage areas being protected by the four sprinklers.

Table A, BS9251, (BS)EN16925, NFPA13D and NFPA13R Wet Pipe Hydraulic Design Criteria

Maximum Coverage Area ^(a) m x m (ft. x ft.)	Maximum Spacing m (ft.)	Minimum Spacing m (ft.)	Ordinary Temperature Rating 72°C (162°F)		Intermediate Temperature Rating 96°C (205°F)		Installation Type	Deflector to Ceiling
			Flow ^(b) L/min (GPM)	Pressure ^(b) bar (psi)	Flow ^(b) L/min (GPM)	Pressure ^(b) bar (psi)		
3.7m x 3.7m (12ft. x 12ft.)	3.7m (12 ft.)	2.4m (8 ft.)	34.0LPM (9 GPM)	0.62bar (9 psi)	34.0LPM (9 GPM)	0.62bar (9 psi)	Concealed	Smooth Ceilings 3/8 to 7/8 Inches.
4.3m x 4.3m (14ft. x 14ft.)	4.3m (14 ft.)	2.4m (8ft.)	41.6 LPM (11 GPM)	0.92bar (13.4 psi)	45.4 LPM (12 GPM)	1.10 bar (16 psi)	Concealed	Beamed Ceilings as per NFPA 13D,13R or 13 Installed in beam 3/8 to 7/8 inches below bottom of beam.

a. For coverage area dimensions less than the above mentioned, it needs to use the minimum required flow for the next higher coverage area listed.
b. Requirement is based on minimum flow in GPM (LPM) from each sprinkler. The associated residual pressures are calculated using the nominal K-Factor. Refer to hydraulic design criteria section for details.

Sprinkler Spacing Criteria

The minimum spacing between sprinklers is 2.4m (8 ft.). The maximum spacing between sprinklers cannot go beyond the coverage area calculated by using the specific hydraulic factors. (Ref. Table A,B)

Residential Lead Free Flat Concealed Pendent, K3.0

Model: RD207

Installation

The Model RD207 must be installed in accordance with the following instructions.

Notes

Do not use any sprinklers which have been subjected to potential mechanical damage. Do not use any sprinklers which show deformation or cracking in either the Sprinkler or the Protective Cap.

Prior to installation, sprinklers should be maintained in the original cartons and packaging until used to minimize the potential for damage to the sprinklers that could cause improper operation or non-operation.

The Protective Cap must remain on the sprinkler during installation. After the installation is completed, the Protective Cap must be removed to place the sprinkler in service.

Use a torque of 9.5 to 19.0 N·m (7 to 14 ft·lbs) to achieve a 1/2" NPT sprinkler joint. If you exceed the recommended maximum torque, this could result in damage to the sprinkler inlet, which may lead to leakage from the sprinkler.

In case of insufficient adjustment in Cover Plate installation, do not try to overly tighten, screw the sprinkler too loosely or make any modification to the cover plate assembly. Readjust the sprinkler fitting for a better fit.

Do not rotate the Cap Removal Tool for RC to the left with force when placing the two hook arms into place. The installed sprinkler may become loosened, which may cause water leakage.

Installation Instructions

Step 1

The installation requirements for the sprinkler are as follows: to be installed only in the pendent position with the waterway perpendicular to the ceiling. Install the sprinkler fitting so that the distance from the face of the fitting to the mounting surface will be nominally 50.8mm (2") as shown in Figure 3.

Step 2

With pipe thread sealant applied to the threads, hand tighten the sprinkler into the sprinkler fitting. Then tighten it with the sprinkler socket or wrench and socket combination (Ref. Figure 4). The grooves of the socket must fit perfectly with the grooves on the sprinkler for proper installation (Ref. Figure 4).

Step 3

If desired the protective cap may also be used to locate the centre of the clearance hole by gently pushing the ceiling material against the centre of the protective cap. Before the installation of the ceiling, the sprinkler installation can be started with the inch 60mm (2 3/8") diameter clearance hole (Ref. Figure 3). Use the 'tolerance limit of ceiling level' indicator on the protective cap to check for proper installation height (Ref. Figure 3).

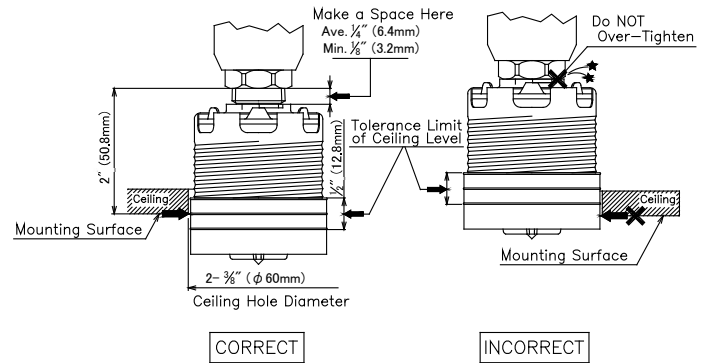

Figure 3

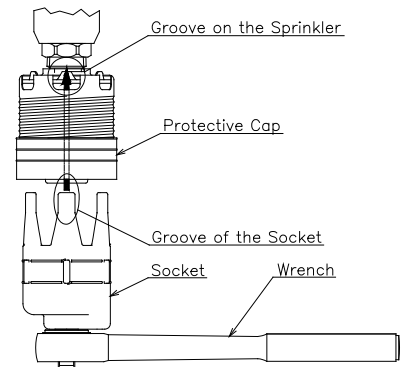

Figure 4

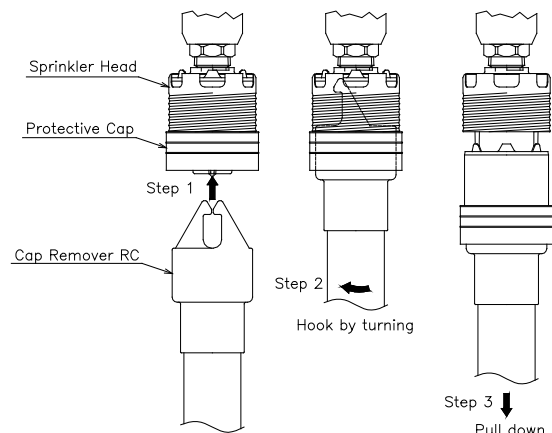

Figure 5

Residential Lead Free Flat Concealed Pendent, K3.0 Model: RD207

Step 4

Use the Cap Remover RC to remove the Protective Cap (Ref. Figure 5), and then push or screw a Cover Plate Assembly on the Cup of the Sprinkler by hand until its flange just comes in contact with the ceiling (Ref. Figure 6 and Figure 7). Stop tightening the Cover Plate Assembly once the flange has come in contact with the ceiling. If the ceiling has been lifted from its normal position in the process of tightening of the Cover Plate Assembly, readjust the cover plate assembly as necessary.

If the flange of the Cover Plate Assembly cannot come in contact with the ceiling sufficiently, readjust the sprinkler fitting as necessary. When properly installed, there is a nominal 1.6mm ($1/16$ inch) air gap between the lip of the Cover Plate and the ceiling, as shown in Figure 6.

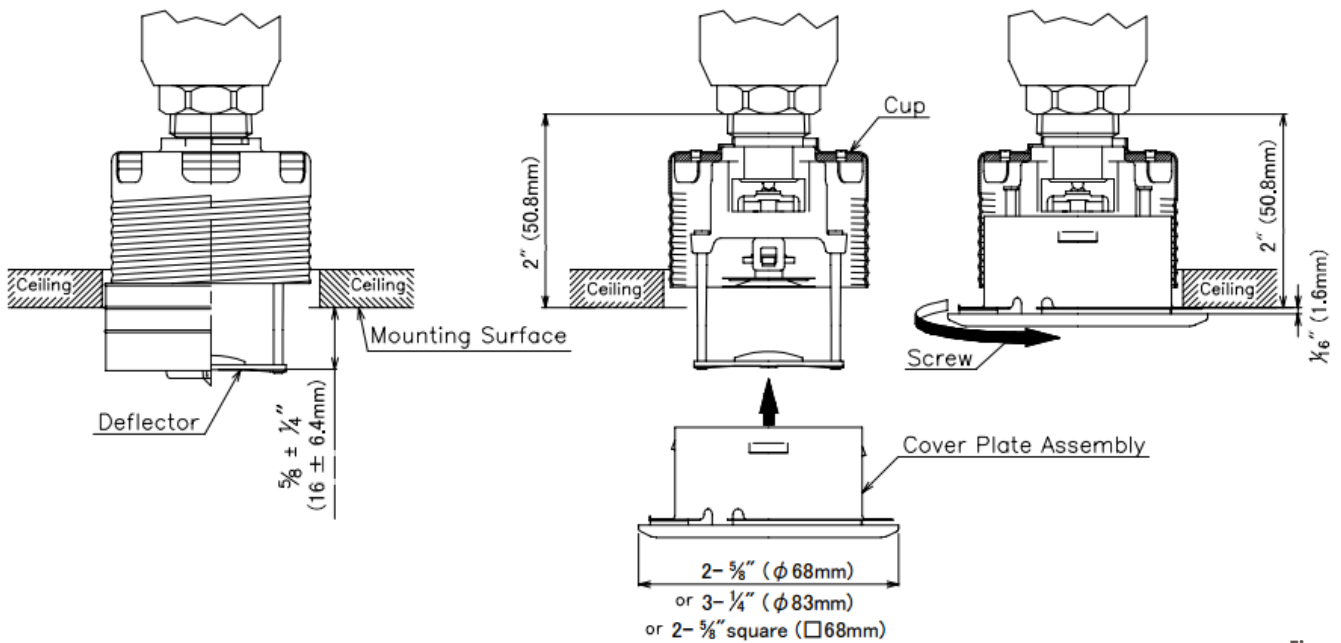

Figure 6

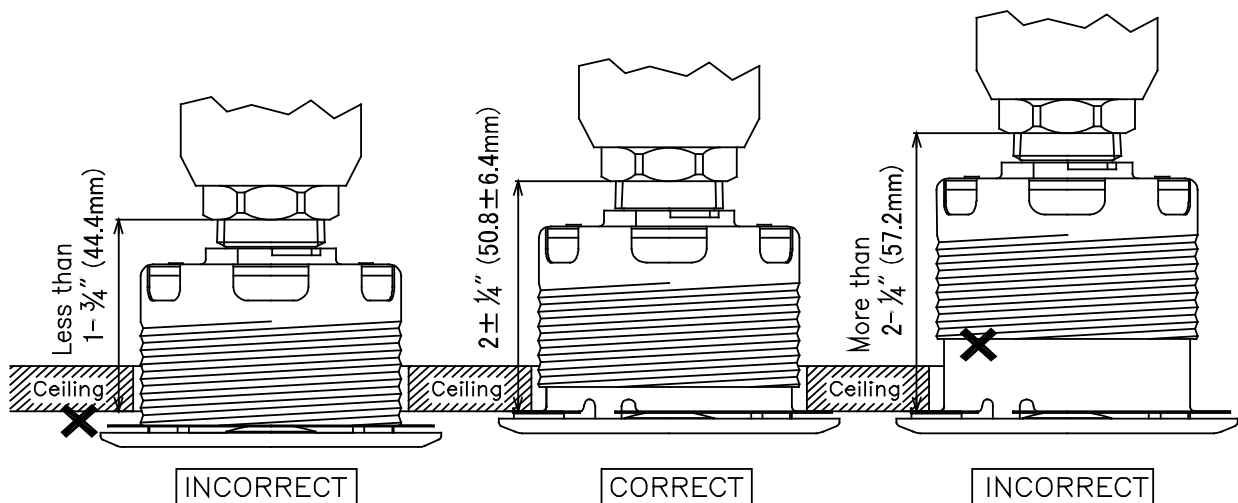

Figure 7



Residential Lead Free Flat Concealed Pendent, K3.0

Model: RD207

Care and Maintenance

The following instructions must be implemented for the maintenance and service of the Model RD207.

Notes

Wet pipe sprinkler systems must be maintained at a minimum temperature of 40°F / 4°C to prevent freezing and bursting of the pipe and/or sprinklers.

Automatic sprinklers are not to be tested with a heat source. Operation of the heat responsive element can result.

Absence of a Cover Plate Assembly may delay the response time of the sprinkler in case of a fire.

Install the cover plate assembly properly, as shown in Figure 6. Improper installation of the cover plate assembly may cause improper operation or non-operation.

If the ceiling is to be repainted after the installation of the Sprinkler, care must be exercised to ensure that the new paint does not seal off any of the air gap.

Factory painted Cover Plates must not be repainted. They should be replaced, if necessary, by factory painted cover plates. Nonfactory applied paint may adversely delay or prevent sprinkler operation in case of a fire.

Do not pull the Cover Plate. Separation may result.

In preparation for maintenance of the fire protection system, permission to close the main control valve must be obtained from the proper authorities, and all affected parties by this action, and must be informed before the maintenance session can commence.

Do NOT enclose any sprinklers within drapes, curtains, or valances.

Do NOT hang anything from the sprinklers.

Do NOT clean the sprinklers with soap and/or water, detergents, ammonia, cleaning fluids, or other chemicals. Remove dust, lint, cobwebs, cocoons, insects, and larvae by gently brushing with a feather duster or gently vacuuming with a soft bristle (i.e., dusting) brush attachment.

Exercise suitable safety precautions in the use and storage of highly flammable materials. The rapid rate of fire development and spread of these materials can reduce the ability of the sprinkler system to aid in the control of a fire involving such hazards.

Leaking or corroded sprinklers must be replaced.

Automatic Sprinklers must be kept in a cool and dry place.

Automatic sprinklers must never be physically altered, such as painted, plated, or coated, once shipped from the factory. If the sprinklers have been in any way modified, they must be replaced.

Great caution must be applied to prevent damage to the sprinklers at all stages - before, during, and after installation. Damaged units because of dropping, hitting, over-tightening, or wrench slippage, must be replaced.

The Model RD207 must only be replaced with pendent sprinklers which are listed for residential fire protection service and which have the same nominal K-Factor, the same coverage area, and the same or lower flow ratings (as indicated under Table A ("Hydraulic Design Criteria")).

When remodeling, such as by adding false beams or light fixtures or changing the location of compartment walls, first verify that the new construction will not violate the installation requirements of the applicable British, European or standards of NFPA. Alter the new construction and/or the sprinkler system to suit the requirements of this document and the applicable British, European or standards of NFPA.

The owner is responsible for the maintenance of the sprinkler system, including inspection and testing of its compliance with this document, as well as the standards of the National Fire Protection Association (e.g., NFPA25), BS9251 or (BS)EN16925 and the regulations of any other authorities having jurisdiction. The owner should direct any questions regarding the above rules and regulations to the installing contractors or the sprinkler manufacturer. It is recommended that automatic sprinkler systems be inspected, tested, and maintained by a qualified Inspection Service in accordance with NFPA25, BS9251 or (BS)EN16925.

Order Procedure

When placing an order, please contact a local distributor with the following information (Model, Temperature Rating and Finish).

Sprinkler Model:

RD207 Residential flat concealed sprinkler, Pendent, K3.0,

Sprinkler Temperature:

72°C (162°F) or

96°C (205°F)

Cover Plate Assembly: (Order Separately from Sprinkler)

Ø68mm (2 5/8") or

Ø83mm (3 1/4") or

Square 68mm (2 5/8")

Cover Plate Temperature:

60°C (140°F) Cover Plate for 72°C (162°F) Sprinkler

72°C (162°F) Cover Plate for 96°C (205°F) Sprinkler

Finish:

White Painted, Chrome or Custom Colour

Tools for Installation:

Socket for Model RD207

Wrench & Socket for Model RD207

Cap Remover for Model RD207